

EVS24
Stavanger, Norway, May 13-16, 2009

Fast Charging vs. Slow Charging: Pros and cons for the New Age of Electric Vehicles

Charles Botsford¹, Adam Szczepanek

¹(corresponding author) AeroVironment Inc., Monrovia, California, botsford@avinc.com

Abstract

This paper presents the issues facing the future widespread use of electric vehicles (EVs) relative to battery charging infrastructure for both fast charging and slow charging. In particular, we discuss:

- Charge scheme definitions: What is fast charging? What is slow charging?
- Infrastructure requirements and grid impacts: The role of connectors, charger/vehicle communications, time-of-use electricity costs, and grid upgrades/synergies.
- The trades between cycle life and charge schemes for the major competing lithium battery chemistries. Pack size versus vehicle cost and charge time. Energy density versus power density. The psychological factors of deploying EV infrastructure that includes both fast and slow charging.

Keywords: lithium battery, fast charge, infrastructure, V2G

1 Introduction

AeroVironment Inc (AV) developed the Impact electric vehicle (EV) for General Motors in 1989. GM then converted the Impact from prototype to the first production-class electric vehicle, EV-1, and marketed it in 1996 and 1999. From the early days of the Impact/EV-1 program, AV focused a great deal of attention on the charging paradigm. Issues included user safety, vehicle safety, battery chemistry, battery management systems, battery pack development, pack testing and

validation, charger power electronics, vehicle/charger interface, inductive vs. conductive charging schemes, and DC delivery methods and connectors.

While the first round of EVs proved unsuccessful for a variety of reasons, the movement provided many valuable lessons relative to the charging paradigm. For example, the question of inductive vs. conductive charging swung overwhelmingly toward conductive in the late-1990s, and has remained so for the new round of EVs.

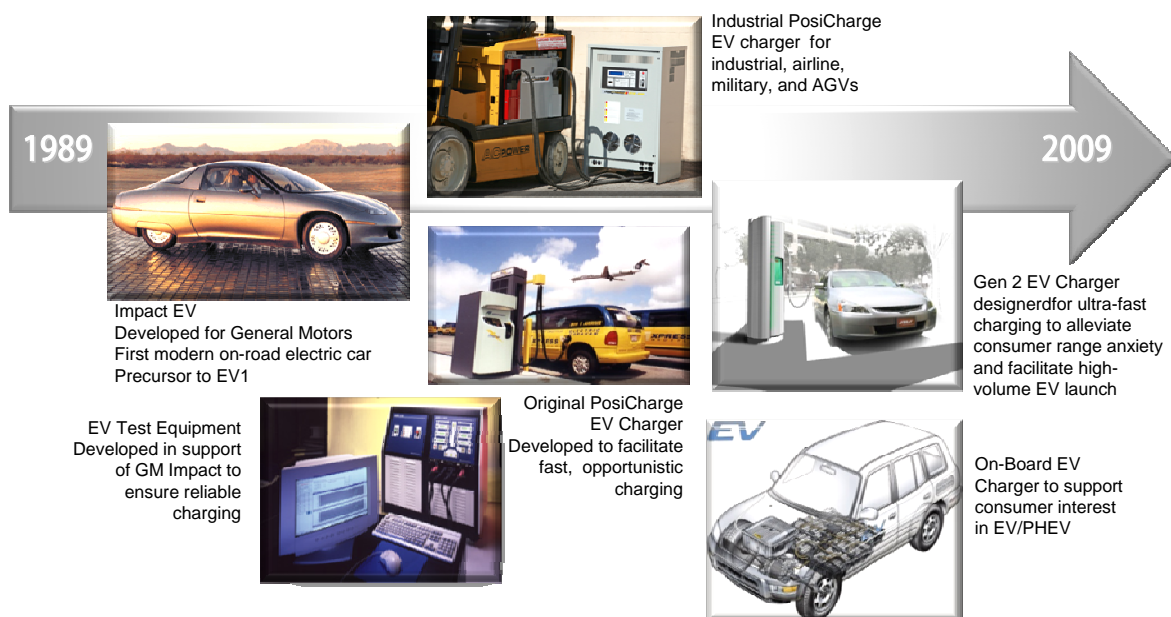

The GM and Toyota EVs (EV-1 and RAV-4) also required off-board chargers that used proprietary inductive paddle charging systems. EVs and plug-in hybrid EVs (PHEVs) planned for near-term product launch will use on-board chargers that convert AC power to the DC power that the batteries require. This is what is typically called slow charging, though Tesla, BMW MiniE and eBox have capability for relatively fast charge through an integrated recharge method.

Electric fork trucks, by no means new to the EV arena, began to emerge at a fast rate in the late-1990s. Slow charging, however, couldn't meet operational needs without using a bulky battery change scheme to rotate three battery packs. Thus, fast chargers developed in the mid-1990s for EVs were modified to charge fork trucks using the "opportunity charging" method. Opportunity charging is now considered the lowest life cycle cost for charging fork trucks and forms the basis for the fast charging model.

2 Charge Scheme Definitions

2.1 Slow Charging

Slow charging is typically associated with overnight charging. This is a definition easy to grasp that translates into a six to eight-hour period.

Slow charging makes use of the EV or PHEV on-board charger, which is sized based on input voltage from the grid. For example, a 120V, 15A (80%) service would supply a 1.4kW charger, while a 240V, 32A service would supply a 6.6kW charger.

How does this translate into recharging the vehicle battery pack? A PHEV with a 5kWh battery pack, for example, would have a 1.4kW on-board charger that allows complete recharge on the order of five hours. An EV with a 40kWh battery pack might have a 6.6kW charger, which allows complete recharging on the order of six to eight hours, depending on thermal considerations and charge algorithms for the battery chemistry.

2.2 Fast Charging

Fast charging could be defined as any scheme other than slow charging. But the real definition, or set of definitions, is much more complex. Table 1 lists a few of the more commonly used terms, which include fast charge, rapid charge, and quick charge. The California Air Resources Board (ARB), in their Zero Emissions Vehicle (ZEV) mandate program, lists a certification requirement for fast charging as a ten-minute charge that enables the vehicle to travel 100 miles.

Table 1: Power Levels for DC Charging

Type of Charge	Charger Power Level, kW		
	Heavy Duty	SUV/Sedan	Small Sedan
Fast Charge, 10 minutes, 100% SOC	500	250	125
Rapid Charge, 15 minutes, 60% SOC	250	125	60
Quick Charge, 60 minutes, 70% SOC	75	35	20
Plug-In Hybrid, 30 Minutes	40	20	10

3 Infrastructure Requirements

EV infrastructure ranges from household electrical plugs to high power appliances that would take the place of today's gasoline pumps. Either scenario would require key infrastructure components as described below.

3.1 The Role of Connectors

The SAE J-1772 committee develops connector standards for plug-in vehicles in the US. The J-1772 Standard comprises three levels:

- Level I – 120V AC;
- Level II – 120V and 240V AC; and
- Level III – DC up to 550A, 600V.

Level I and II connectors fall into the category of slow charging, with one possible caveat, which is the potential of allowing Level II DC charging. These connector levels correspond to the types of charging listed above. For example, a 6.6kW on-board charger for an EV would likely need a Level II connector, while charging an EV in ten minutes would require a Level III connector.

Level III connectors enable fast charging. The receptacle (vehicle side) will fit the fuel inlet compartment with the mounting flange less than 4" diameter. Figure 1 depicts an example of a Level III vehicle-side connector.

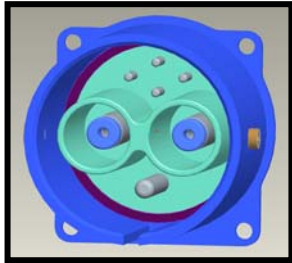

Figure 1: Level III DC Vehicle-Side Connector

AC, via Level I and II connectors supply the EV on board charger. With Level III, however, the high power fast charger, via a Level III connector, directly supplies the EV battery pack with DC power, enabling power and communications flow. A Level II connector enabled for both AC and DC, with the proper vehicle wiring, would allow power to flow directly to the battery pack, thus bypassing the vehicle on-board charger.

In Europe, International Electrotechnical Commission (IEC) 61851 applies to equipment for charging electric road vehicles at standard AC supply voltages (as per IEC 60038) up to 690 V and at DC voltages up to 1,000 V, and for providing electrical power for any additional services on the vehicle if required when connected to the supply network. IEC 61851 promotes different charging levels analogous to SAE J1772. Coordination between SAE J1772 and IEC 61851 is ongoing. The Japan Automotive Research Institute, JARI, also actively participates in setting EV charging standards.

3.2 Charger/Vehicle Communications

SAE J1850 established the communications protocol between DC chargers and EVs in the 1990s. The SAE J2293 committee is in the process of developing an updated communications protocol that accounts for methods, such as communications-over-power line, that have now emerged as viable. The SAE J2836 committee is developing a communications protocol between Level II outlet and PHEV on-board charger.

3.3 Time-of-Use Electricity Costs

Utilities are moving toward Advanced Metering Infrastructure (AMI) that will allow for “time-of-

use” electricity rates on a wide scale. AMI would enable utilities to charge much higher rates at peak usage, say summer afternoons, versus low rates at 2:00 A.M.

This capability provides an enormous economic driving force for both the utility and the consumer. The consumer pays a very large penalty to use electricity at peak rates, making non-peak electrical usage attractive.

Non-peak rates typically occur at night, while the consumer sleeps. Thus, charging an EV or PHEV at night provides both convenience and low electricity rates. For these reasons, conventional wisdom opines that the vast majority of future EV/PHEV charging will happen at night. This, also, is where Level I and II charging infrastructure will be most prevalent.

Consumers will no doubt need to charge their vehicles during the daytime, which will drive the requirement for public charging infrastructure at all charging levels.

In addition to time-of-use rates, utilities and/or charging service providers will likely bill based on the power level of electricity provided. For example, a slow charge at 120V, 15A would undoubtedly cost less per kWh than a DC fast charge at 125kW.

Already, however, promoters have begun to develop business models that would minimize the impact of electricity costs. Placing advertising on the charger, or billing for the parking slot are examples of schemes that would offset infrastructure and electricity costs.

3.4 Grid Impacts and Synergies

AMI also provides a powerful market tool for utilities to control the grid. One potential scheme, as mentioned above, would be for a utility to bill based on how loaded the grid might be at a given time. In addition to influencing consumer behaviour through pricing, the utility could be given control of individual chargers (Level II and III) such that no charging could occur if the utility anticipated a brown-out condition.

Negative Impacts? One pervasive fear is that fast charging, or even Level II charging could negatively impact the grid. However, extensive modelling [1] has shown minimal real impact to the grid. Figure 2 depicts the hierarchy for a generic electricity network in the US. Figure 3 depicts six 250kW fast chargers—possibly a replacement for a gasoline station someday.

If all six fast chargers operated simultaneously at full output, they would require about 1.5MW DC, or about 33A at the local 26kV AC line. The capacity for this line is typically 600-900A. Thus, in the event of such an occurrence, only a small portion, maybe 5%, of the local line capacity would be used.

grid and the charger bank, as detailed in a recently issued patent [2], could provide a buffer and further reduce the potential for adverse grid impacts. Indeed, utility control coupled with a high peak use rate structure ensures that fast charging will have minimal grid impacts.

In addition to not threatening the grid, charging schemes that include battery storage between the

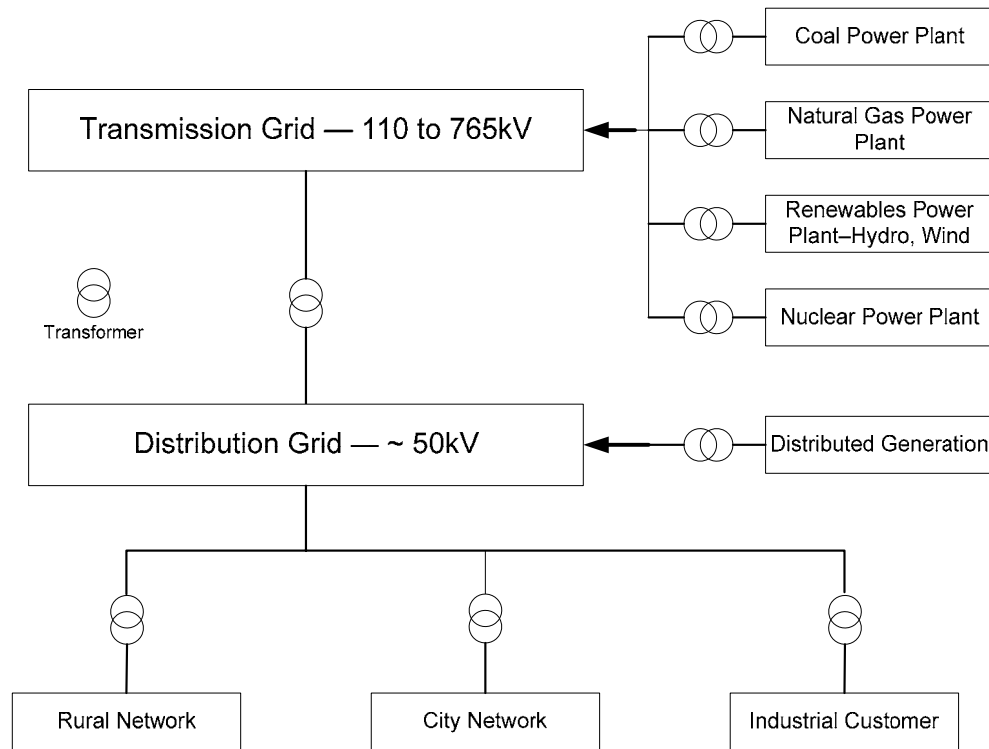

Figure 2: Generic electricity network

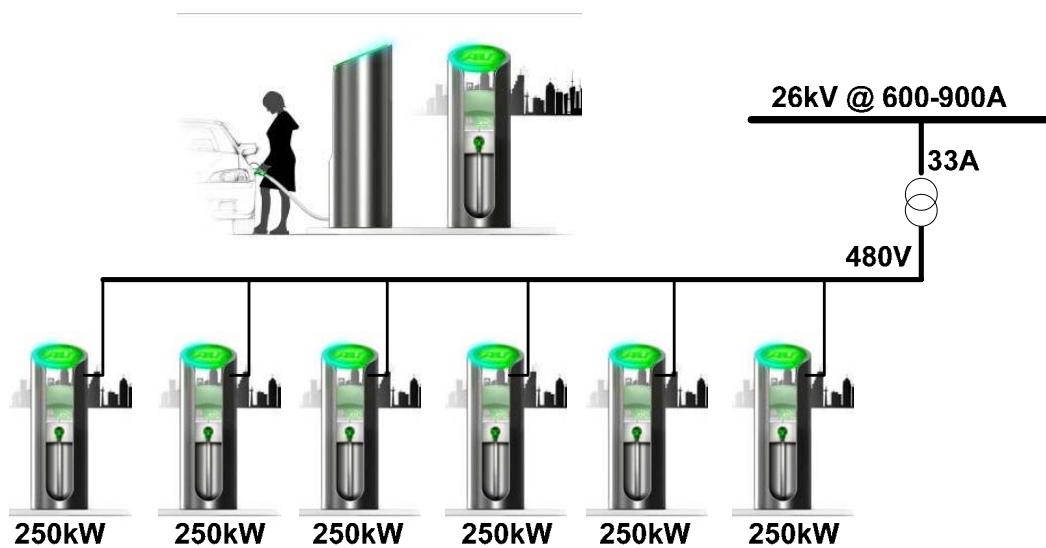

Figure 3: Six 250kW EV fast chargers on a 26kV low voltage neighbourhood line

What if everybody—millions—charge at night? Utilities have well founded worries relative to system-wide grid impacts from the millions of future EVs and PHEVs charging their batteries—even at night. Indeed, most regional US grids have ample night-time surplus capacity that would allow the addition of EVs and PHEVs for foreseeable future without the addition of generation or grid capacity. Long term, the favourable night-time time-of-use economics could change to close the gap between day time use and the low use valley at night. However, would it change enough to modify behaviour, especially when the convenience of night-time charging is considered?

Grid Synergies. Enabling utility control to protect and enhance grid operations, along with consumer control to operate their vehicles would appear to be an ideal synergy.

Movements toward smart grids and communications at every level are progressing rapidly. Rather than a detriment, EVs and PHEVs could enhance the grid and provide stability. Bi-directional methods, called vehicle-to-grid (V2G), vehicle-to-home (V2H), and others would enable EVs and PHEVs to act as a massive energy storage device for the grid. A simpler, uni-directional method [3] would allow grid ancillary services such as grid regulation through mere on-off charger control by the utility or grid operator, through an aggregator.

For potential future V2G infrastructure, all levels of EV chargers, including on-board chargers, will need to be capable of bi-directional power flow. [4, 5, 6, 7]. One method of on-board charging is the integrated recharge method that uses the traction inverter together with the motor's inductance, which obviates the need for a separate on-board charger. This method is bi-directional by design and was originally developed by AC Propulsion.

Renewables. While still a small percentage of the absolute electricity power generation mix in the US, the increase of wind energy coming on line as a percentage of incremental new installed power generation is very encouraging. From 2005 to 2007, the percent of total new power generation attributable to wind energy rose from 10% to 33% as shown in Figure 4. The wind capacity added in 2008 was 7500MW, which would exceed 40% of all power generation coming on line for 2008 [8].

Over the next decade, as wind and other renewables become a more important contributor

to the electricity power generation mix, the question of grid impacts must be addressed. In the current grid configuration, wind energy may be limited to 20% of the total power generation mix. A new mechanism that allows a much greater penetration of wind energy and other renewables to contribute to the grid would be valuable.

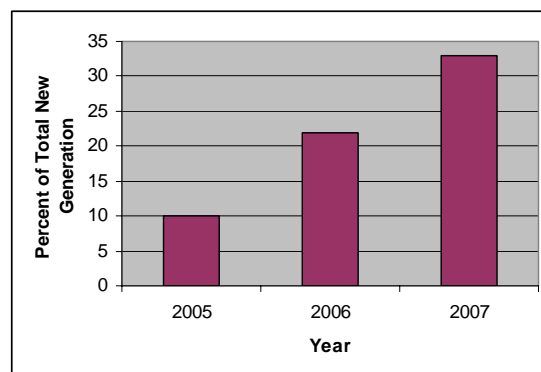

Figure 4: Wind generation as a percentage of the total US power generation coming on line for a given year

Wind, solar, hydro, geothermal and other renewables provide an opportunity to work in synergy with the grid through the use of energy storage such as EVs and PHEVs. Wind, in particular, while considered a non-dispatchable, intermittent power source, could overcome these disadvantages via EVs and PHEVs. Several US utilities are conducting demonstrations on the MW scale using large batteries as buffers between wind farms and the grid, which show the potential benefit of using EVs and PHEVs to provide grid services [9]. This, also does not require bi-directional power flow.

4 Cycle Life, Charge Schemes, and Cost for Lithium Battery Chemistries

Batteries are the primary reason EVs are not the vehicles we drive today. Cost and range issues have hampered mass adoption. The latest advances in lithium chemistries promise answers to these issues. Will it be enough to beat other transportation alternatives? Will it happen soon?

4.1 Iron Phosphate, Lithium Titanate, but What's Next?

Since the days of lead acid and nickel metal hydride batteries used in the GM EV-1, the search for batteries with higher energy density has been unending. In fact, hybrid vehicles such as the Toyota Prius and Honda Civic still use nickel

metal hydride batteries. Nickel metal hydride, however, in addition to relatively low energy density, also contains nickel, an expensive material. Three of the more popular lithium based electrochemical systems vying for EV applications are lithium cobalt or lithium manganese oxides (standard format), lithium iron phosphate, and lithium titanate.

Batteries such as those for laptop computers and cell phones, which use standard format lithium cells would seem to be the obvious solution because they have a relatively low cost and very high specific energy. In fact, a concept developed by AC Propulsion using “bricks” of 18650 computer cells configured into large packs has been adopted by both BMW (Mini Cooper) and Tesla Motors. Computer cells, which are manufactured by the billions in Asia, have disadvantages. Due to safety and performance reasons they are limited to one- to two-hour charge rates at the pack level so as not to impact cycle life.

Lithium iron phosphate batteries are manufactured by many companies worldwide and have gained credibility through their use in power tools. Lithium iron phosphate cells have a much lower energy density than standard format cells, but can be charged much faster—on the order of twenty to thirty minutes.

Lithium titanate batteries allow charging on the order of ten minutes and have been shown to have extremely long cycle life—on the order of 5000 full depth of discharge cycles. Lithium titanate has high inherent safety because the graphite anode of standard format and iron phosphate batteries is replaced with a titanium oxide.

Figure 5 shows the pack level specific energy of EV batteries as a function of charge rate, called “C”. A “one C” charge rate is the time it takes to charge a battery in one hour. A C/2 charge rate requires two hours, while a 6C charge rate requires only ten minutes. The values in Figure 5 are approximate, as shown by the error bars, and depend on many factors such as State of Charge and battery chemistry.

4.2 Range vs. Pack size

Batteries, even lead acid batteries, are expensive. The larger the battery pack, the more expensive it is. What is the right size for an EV battery pack? Figure 6 shows EV range per charge versus pack size for a variety of EVs. One measure of EV efficiency is Wh/mi on a plug-to-wheels basis. The lower the Wh/mi, the more efficient the EV drive train. A smaller, less expensive battery pack may one day allow the full functionality of today’s conventional vehicles if fast charging is part of the equation.

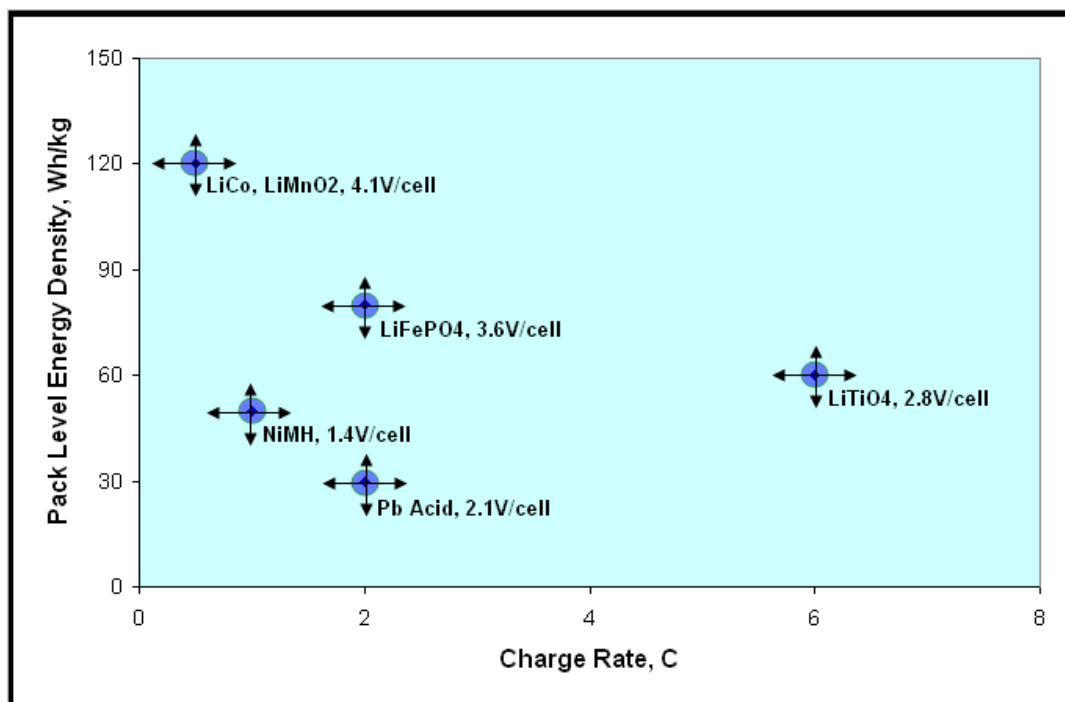

Figure 5: Pack level specific energy versus charge rates for different battery chemistries

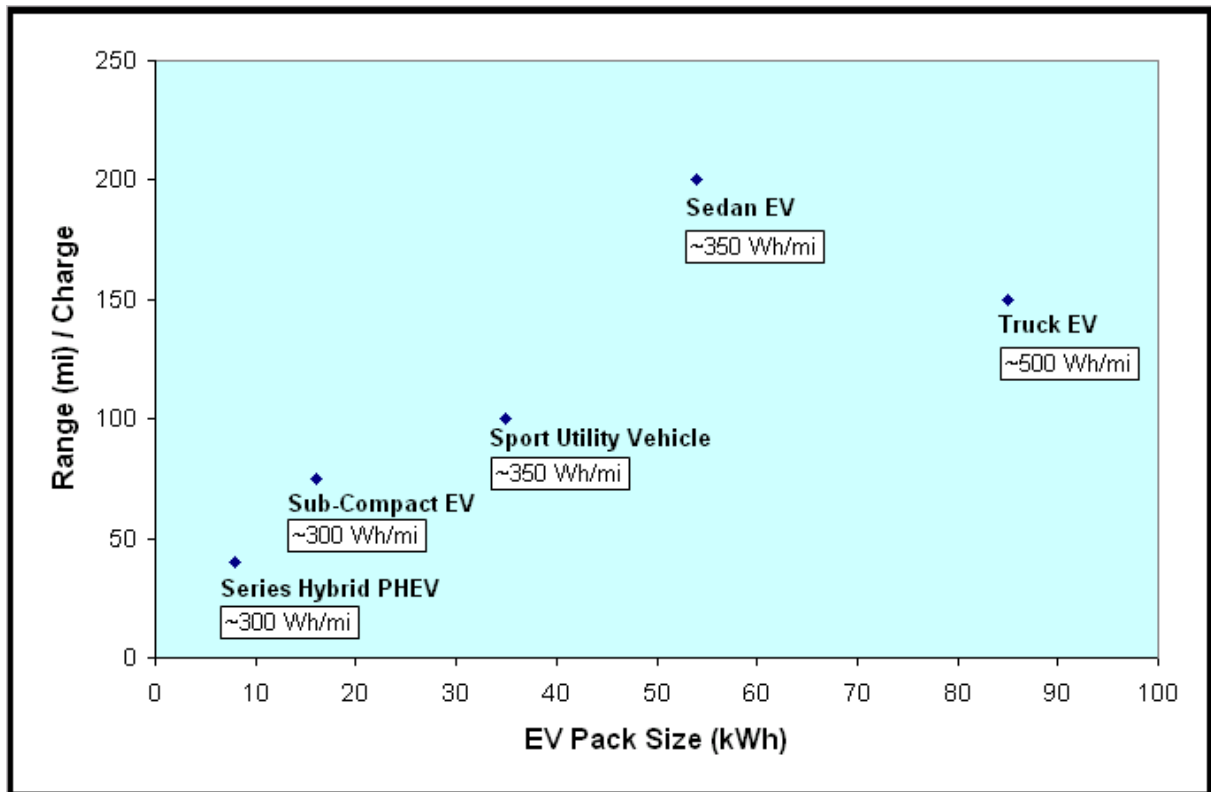

Figure 6: Vehicle range versus pack size at different vehicle efficiencies—“mileage”

5 The Implications of Electric Vehicle Acceptance Relative to Fast Versus Slow Charging

Tokyo Electric Power Company (TEPCO) has been at the forefront of EV infrastructure development and deployment. The company conducted a year-long study of fast charging infrastructure that began in October 2007 [10]. To investigate the deployment and operation sequence of a fleet of Mitsubishi EV service vehicles.

TEPCO targeted conventional internal combustion engine (ICE) service vehicles for substitution with EVs for reasons of greenhouse gas reductions, higher efficiency operations, lower maintenance, and reduced petroleum product usage. The conventional ICE service vehicles operated with essentially unlimited access over the entire 8 x 15 km service area.

When the EV service vehicles were introduced in October 2007, they were charged overnight at the TEPCO facility using slow chargers. However, after several months, TEPCO found that the EV

service vehicle drivers accessed only a small portion of the service area as shown in Figure 7.

The study plan called for the addition of a fast charger to recharge service vehicles during the day. After the fast charger was installed in March 2008, as shown in Figure 8, the EV service vehicle drivers began accessing the entire service area, as did the conventional ICE service vehicles.

Interestingly, TEPCO reports that the second charger was used only sparingly. This illustrates a phenomenon described as “range anxiety.” In this case, just knowing that the EV service vehicle could be recharged during the day reassured EV drivers that they would not be stranded.

Prior to installation of the fast charger, drivers returned their vehicles at a battery State of Charge (SOC) much greater than 50%. After the second charger installation, the SOC shifted to below 50%. This is further evidence of the largely psychological effect provided by the fast charger.

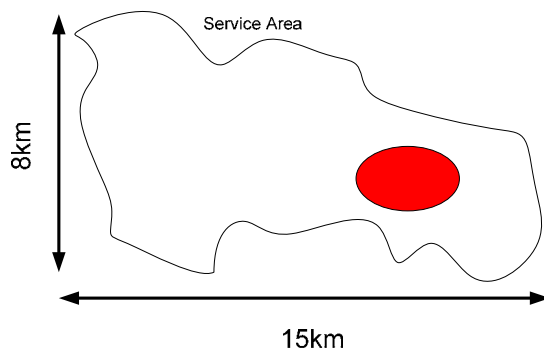

Figure 7: Service Area accessed by EV w/Slow Charger

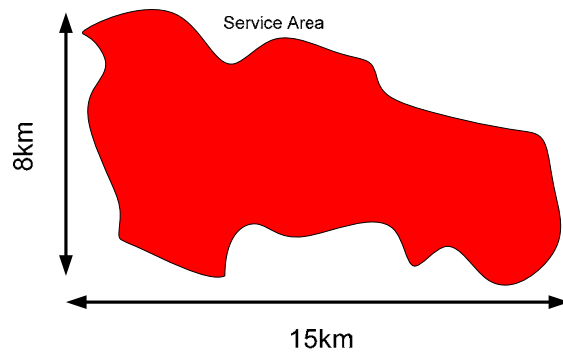

Figure 8: Service Area accessed after Fast Charger added

6 Conclusions

In the EV world of the future, Level I and II slow charging will likely be the most used schemes because of convenience and low-cost electricity. However, Level III fast charging provides a method to alleviate “range anxiety” for the driver of passenger EVs and will likely be a necessity for many types of fleet drivers—especially taxis.

In one ten-minute charge cycle, a fast charger can provide enough energy to allow a passenger EV to operate for one hundred miles. This fast charge capability can help to enable rapid growth of the EV market by minimizing vehicle downtime.

The TEPCO study shows an example of how limiting the slow charging-only paradigm can be. If one fast charger can impact the psychology of a set of fleet drivers, a full build-out of EV fast charge infrastructure will enable a wide adoption of EVs. Fast charging opens the horizon of the new age of EVs.

Acknowledgements

The authors wish to thank Dr. Etezadi and TEPCO for their kind assistance.

References

- [1] Etezadi, 2009. University of Nevada, Reno. Communication with AeroVironment staff February 2009, pre-published report on grid impacts from fast charging.
- [2] US Patent Office, US Patent 7256516 - Battery charging system and method.
- [3] Brooks, Alec and Sven Thesen, Dec 2007. PG&E and Tesla Motors: Vehicle to Grid Demonstration and Evaluation Program, presented at EVS23.

- [4] Kempton, W. and Steven Letendre. 1997. "Electric Vehicles as a New Source of Power for Electric Utilities" *Transportation Research* 2(3): 157-175.
- [5] Brooks, Alec, 2002. "Vehicle-to-Grid Demonstration Project: Grid Regulation Ancillary Service with a Battery Electric Vehicle" Report, AC Propulsion, December 2002. Sponsored by CARB.
- [6] Jasna Tomić and Willett Kempton, proof (with minor errors): "Using fleets of electric-drive vehicles for grid support" *Journal of Power Sources*, doi: 10.1016/j.jpowsour.2007.03.010.
- [7] Chuang, A., J. Hughes, M. McGranaghan, and X. Mamo., 2008. *Integrating New and Emerging Technologies into the California Smart Grid Infrastructure*. EPRI, Palo Alto, CA; California Energy Commission, Sacramento, CA. 1016535, CEC 500-2008-047.
- [8] Energy Biz Magazine, November/December 2008, p.92. "Renewables and Gas Generation Surge".
- [9] Minnesota Daily/UWire, 1 April 2009. "U. Minnesota researchers study nation's first wind-to-battery storage".
- [10] Tokyo Electric Power Company. Communication with AeroVironment staff March 2009. Effects of fast chargers on an EV fleet.

Authors



**Mr. Charles Botsford, P.E., M.S.,
Chemical Engineering.** Mr. Botsford is a professional chemical engineer (California) with 30 years experience in engineering design, distributed generation, and environmental management. He has a wide range of experience relative to renewable energy systems, electric vehicles, power electronics, and air quality issues. Mr. Botsford conducts business development for AeroVironment and is a Qualified Environmental Professional (QEP), Emeritus.



**Mr. Adam Szczepanek, M.S.,
Electrical & Mechanical Engineering.** Mr. Szczepanek is an electrical engineer specializing in power systems with over 18 years of experience. He has a strong background in power electronics, electrical interconnection, electronic control systems, mechanical components, turbomachinery, generators/motors, and supplier management. Mr. Szczepanek conducts business development for AeroVironment's EV Solutions group.